

# Installation Manual

# ASCO® 3ATS & 3NTS E-design 260-400 A Transfer Switches

## DANGER

DANGER is used in this manual to warn of a hazard situation which, if not avoided, will result in death or serious injury.

## WARNING

WARNING is used in this manual to warn of a hazardous situation which, if not avoided, could result death or serious injury.

## CAUTION

CAUTION is used in this manual to warn of a hazardous situation which, if not avoided, could result in minor or moderate injury.

Refer to the outline and wiring drawings provided with the 3ATS or 3NTS for all installation and connection details and accessories.

Refer to **User's Guide 381333-400** for the Group G Controller status display messages, time delays, pickup and dropout settings, and adjustments.

### 3ATS

The 3ATS is an automatic transfer switch. It includes transfer test, generator start/stop control, and generator exerciser.

### 3NTS

The 3NTS is an electrically-operated manual transfer switch (non-automatic). It does not include generator start/stop control and generator exerciser.

## Rating Label

Each transfer switch contains a rating label to define the loads and fault circuit withstand/closing ratings. Refer to the label on the transfer switch for specific values.

## WARNING

Do not exceed the values on the rating label. Exceeding the rating can cause person injury or serious equipment damage.

An experienced licensed electrician must install the transfer switch.

## Table of Contents

INSTALLATION	
Mounting .....	2
Power Connections .....	2
Engine Starting Contacts .....	3
FUNCTIONAL TEST	
1- Manual Operation .....	3
2- Voltage Checks .....	4
3- Electrical Operation .....	5
TESTING & SERVICE	
Transfer Test .....	6
Preventive Maintenance .....	6
Manual Load Transfer .....	6
TROUBLESHOOTING .....	7
INDEX .....	8

**381333-403 A**

## Installation

These transfer switches are factory wired and tested. Installation requires mounting, connecting service cables, and connecting engine start and auxiliary control circuits (if required.).

### Supporting Foundation

The supporting foundation for the enclosure must be level and straight. Refer to the applicable enclosure outline drawing included with the transfer switch for all mounting details including door opening space.

If bottom cable entry is used, the foundation must be prepared so that the conduit stubs are located correctly. Refer to the enclosure outline drawing for specified area and location. Provide cable bending space and ½ inch minimum clearance to live metal parts. When a concrete floor is poured, use interlocking conduit spacer caps or a wood or metal template to maintain proper conduit alignment.

### Mounting

Refer to the outline and mounting diagram and mount the transfer switch according to details and instructions shown on the diagram. Mount it vertically to a rigid supporting structure. Level all mounting points by using flat washers behind the holes to avoid distortion of the transfer switch.

An insulator backing piece must be installed behind the transfer switch. If the transfer switch is removed from the enclosure and then reinstalled, this insulator piece must be placed behind the transfer switch. See Figure 1.



Be sure that the insulator piece is behind the transfer switch.

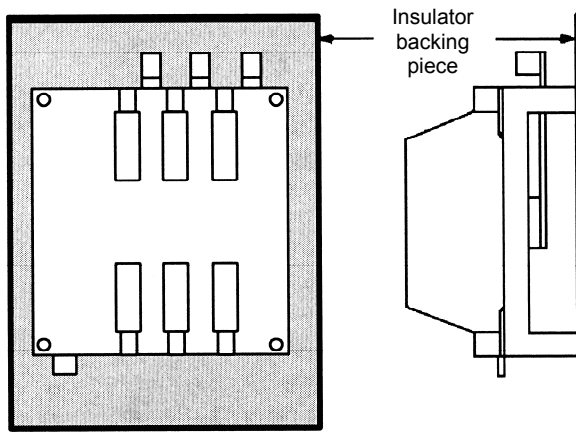

Figure 1. Required insulator backing piece.

### NOTICE

Protect the transfer switch from construction grit and metal chips to prevent malfunction or shortened life of the transfer switch.

### Line Connections

Refer to the wiring diagram provided with the transfer switch. All wiring must be made in accordance with the National Electrical Code and local codes.



De-energize the conductors before making any line or auxiliary circuit connections. Be sure that the Normal and Emergency line connections are in proper phase rotation. Place the engine generator starting control in the OFF position. Make sure engine generator is not in operation.

### Testing Power Conductors

Do not connect the power conductors to the transfer switch until they are tested. Installing power cables in conduit, cable troughs, and ceiling-suspended hangers often requires considerable force. The pulling of cables can damage insulation and stretch or break the conductor's strands. For this reason, after the cables are pulled into position, and before they are connected, they should be tested to verify that they are not defective or have been damaged during installation.

### Connecting Power Cables

After the power cables have been tested, connect them to the appropriate terminal lugs on the transfer switch as shown on the wiring diagram provided with the transfer switch. Make sure that the lugs provided are suitable for use with the cables being installed. Standard terminal lugs are solderless screw type and will accept the wire sizes listed on the drawings provided with the transfer switch. Be careful when stripping insulation from the cables, avoid nicking or ringing the conductor. Remove surface oxides from cables by cleaning with a wire brush. When aluminum cable is used, apply joint compound to conductors. Tighten cable lugs to the torque specified on rating label.

Do not run cables behind the transfer switch. Cables can be bundled on the right side. Maintain proper electrical clearance between the live metal parts and grounded metal: ½ inch minimum.

### Controller Ground

A grounding wire must be connected to the controller’s lower left mounting stud. Because the controller is mounted on the enclosure door, a conductive strap must be used between the enclosure and the door. This connection provides proper grounding which does not rely upon the door hinges.

### Engine Starting Contacts

The engine control contact connections (if used) are located on top of the transfer switch. Connect signal wires to appropriate terminals as specified in Table A and shown in Figure 2.

Table A. Engine Start Connections.

When normal source fails	Terminals on transfer switch
contact closes	TB14 and TB15
contact opens	TB14 and TB16

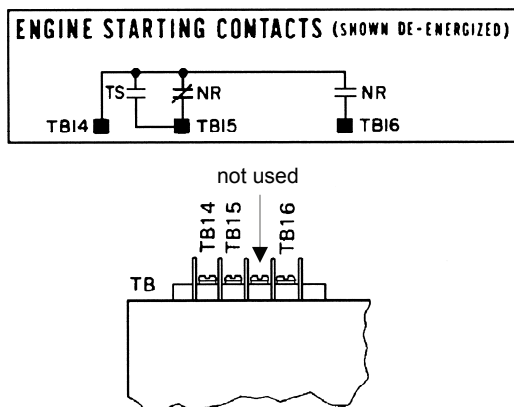

Figure 2. Engine starting contact label and location on the top of transfer switch.

### Harnesses

The transfer switch is connected to the left side of the controller by a plug-in harness (two plugs).

### Auxiliary Circuits

Connect auxiliary circuit wires to appropriate terminals on the transfer switch as shown on the wiring diagram.

Read all instructions on the wiring diagram and labels affixed to the transfer switch. Note the control features that are provided and review their operation before proceeding.

## Functional Test

The functional test consists of three checks: manual operation, voltage checks, and electrical operation.

### NOTICE

Do these checks in the order presented to avoid damaging the transfer switch.

### 1 – Manual Operation

A detachable maintenance handle is provided on the transfer switch for maintenance purposes only. Manual operation of the transfer switch should be checked before it is energized (operated electrically).

### ! WARNING

Do not manually operate the transfer switch until both power sources are disconnected: open both circuit breakers.

1. After deenergizing both power sources, open the enclosure door. Locate the maintenance handle on the left side of the transfer switch. Insert the maintenance handle into the hole in the shaft, left side of the operator. See Figure 3
2. Move the maintenance handle up or down as shown to manually operate the transfer switch. It should operate smoothly without any binding. If it does not, check for shimming damage or construction debris.
3. Return the transfer switch to the Normal position. Remove the maintenance handle and store it on the left side.

### NOTICE

Verify that the maintenance handle has been removed before proceeding!

Note: If Normal and Emergency connections are reversed this operation is also reversed.

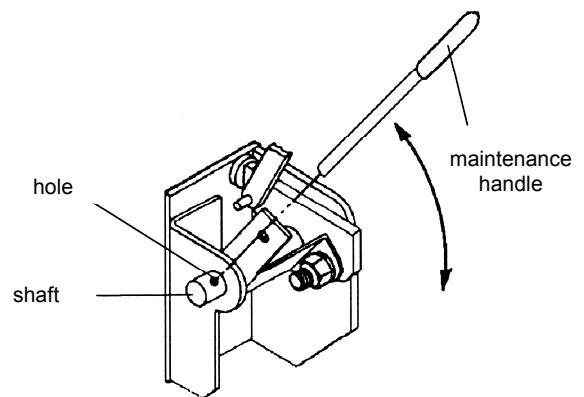

Figure 3. Maintenance handle and positions.

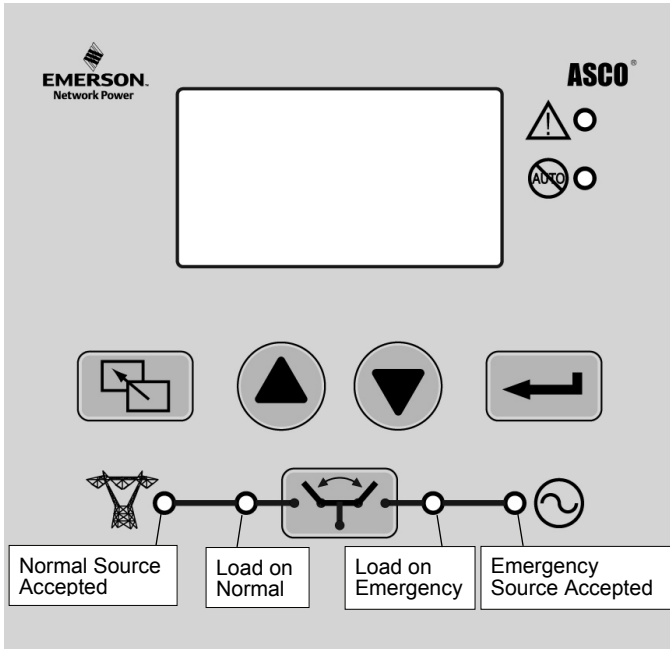

Figure 4. Four indicator lights.

## 2 – Voltage Checks

First check the nameplate on the transfer switch; rated voltage must be the same as normal and emergency line voltages.



Use extreme caution when using a meter to measure voltages in the following steps. Do not touch power terminals; shock, burns, or death could result!

Perform steps 1 through 6 at the right. Observe the indicator lights. See Figure 4.

- Black circle means the light is on.
- White circle means the light is off.

\* If necessary, adjust the voltage regulator on the generator according to the manufacturer’s recommendations. The transfer switch will respond only to the rated voltage specified on the transfer switch nameplate.

Also see User’s Guide 381333-400 for voltage settings in the controller.

1	<p>Close the normal source circuit breaker. The normal source accepted and the load on normal lights should come on.</p>
2	<p>Use an accurate voltmeter to check phase to phase and phase to neutral voltages present at the transfer switch normal source terminals.</p>
3	<p>Close the emergency source circuit breaker. (Start generator, if necessary.) The emergency source accepted light should come on.</p>
4	<p>Use an accurate voltmeter to check phase to phase and phase to neutral voltages present at the transfer switch emergency source terminals.*</p>
5	<p>Use a phase rotation meter to check phase rotation of emergency source; it must be the <u>same</u> at the normal source.</p>
6	<p>Shut down the engine-generator, if applicable. The emergency source accepted light should go off. Then put the starting control selector switch (on the generator set) in the automatic position. Close the enclosure door.</p>

Continue to **3 – Electrical Operation** on the next page.

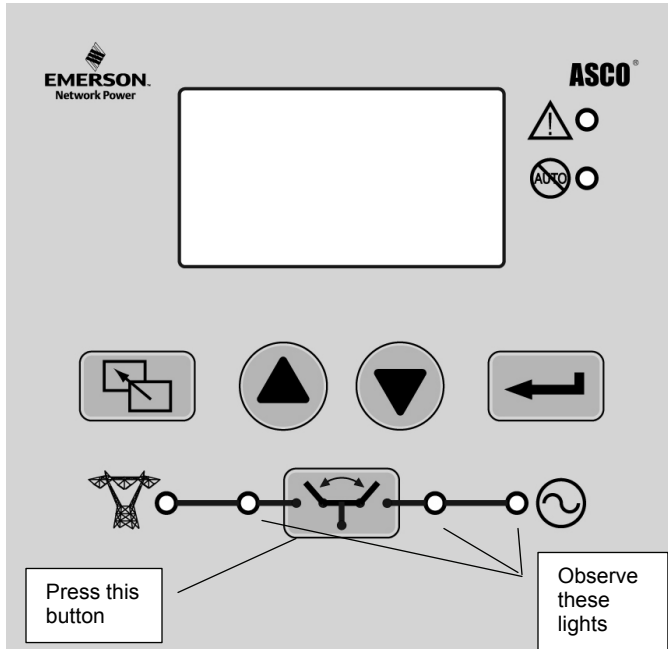

Figure 5. Transfer button and indicator lights.

### 3 – Electrical Operation

This procedure will check the electrical operation of the transfer switch.

**WARNING**

Close the transfer switch enclosure door and tighten the screws before you test electrical operation.

Perform steps 1 through 5 at the right. Observe the status lights. See Figure 5.

- Black circle means light is on.
- White circle means light is off.

**NOTE:** For 3NTS manually start the emergency generator at the generator. Then press the transfer button for load transfer. If the inphase transfer feature is activated, transfer may not occur immediately. Transfer will occur when the phase relationship between sources is correct. Press the transfer button again for load retransfer to normal, then manually stop the generator at the generator.

Also see User’s Guide 381333-400 for inphase transfer and time delay settings in the controller.

This completes the functional test of the transfer switch. Leave the engine-generator starting control in the automatic position.

1	<p>The normal source must be available and the generator must be ready to start. Check that the normal source accepted light is on.</p>
2	<p>For 3ATS press the transfer button. The engine should start and run within 15 seconds. For 3NTS the generator must be started manually at the generator.</p> <p>The emergency source accepted light should come on.</p>
3	<p>For 3ATS the transfer switch should transfer to the emergency position. The load on emergency light should come on and the load on normal light should go off. For 3NTS press the transfer button for load transfer.</p> <p>If the transfer to emergency delay is used, the transfer occurs after a time delay. For immediate transfer (bypass timer) press the transfer button again.</p>
4	<p>For 3ATS the transfer switch should transfer back to the normal position. The load on normal light should come on and the load on emergency light should go off. For 3NTS press the transfer button for load retransfer.</p> <p>If the retransfer to normal delay is used the retransfer should occur after a time delay. For immediate retransfer (bypass timer) press the transfer button again.</p>
5	<p>For 3ATS the unloaded running delay keeps the generator running for a cool-down period. Then the generator should stop and the emergency source accepted light should go off. For 3NTS manually stop the generator at the generator (after a cool-down period).</p>

## Testing & Service

### Transfer Test

Operate the transfer switch at least once a month by following the *Electrical Operation* procedure on page 5.

### Preventive Maintenance

Reasonable care in preventive maintenance will insure high reliability and long life for the transfer switch. An annual preventive maintenance program is recommended.

ASCO Services, Inc. (ASI) is ASCO Power Technologies' national service organization. ASI can be contacted at 1-800-800-2726 for information on preventive maintenance agreements.

### Yearly Inspection

#### DANGER

Hazardous voltage capable of causing shock, burns, or death is used in this transfer switch. Deenergize both Normal & Emergency power sources before performing inspections!

**Clean the enclosure.** Deenergize all sources, then brush and vacuum away any excessive dust accumulation. Remove moisture with a clean cloth.

**Inspect the transfer switch contacts.** Deenergize all sources, then remove the transfer switch barriers and check the contact condition. Replace contacts when pitted or worn excessively. Reinstall the barriers carefully.

**Maintain transfer switch lubrication.** Under normal operating conditions no further lubricating is required. Renew factory lubrication if the transfer switch is subjected to severe dust, abnormal operating conditions, or if the TS coil is replaced. Order lubrication kit 75-100.

**Check all cable connections & retighten them.** Torque to values shown on the transfer switch label.

## Replacement Parts

When ordering replacement parts provide the Serial No., Bill of Material No. (BOM), and Catalog No. from the transfer switch nameplate. In the US call 800-800-2726 (ASCO) or contact [customercare@asco.com](mailto:customercare@asco.com).

### Manual Load Transfer

This procedure will manually transfer the load if the controller is disconnected.



#### WARNING

Do not manually operate the transfer switch until both power sources are disconnected: open both circuit breakers.

1. Deenergize both the normal and emergency source (open both circuit breakers).
2. Use the maintenance handle to manually operate the transfer switch to the opposite source. See page 4, *Manual Operation*.
3. Close the enclosure door. If the transfer switch is in the emergency position, manually start the generator and then close the emergency source circuit breaker.



# Troubleshooting

Problem	Check in Numerical Sequence		
	1 Operation	2 Generator	3 Voltage
For 3ATS the generator set does not start when the transfer button is pressed or when the normal source fails.	The outage must be long enough to allow for the feature 1C time delay plus engine cranking and starting time.	Starting control must be in automatic position. Batteries must be charged and connected. Check wiring to the engine starting contacts.	-
For 3ATS the transfer switch does not transfer the load to the emergency source after the generator starts.	Wait for the feature 2B time delay. For immediate transfer, press the transfer button (bypass timer). If inphase transfer is active, wait for inphase condition. For 3NTS press the transfer button.	Is the emergency source accepted light on? Generator output circuit breaker must be closed. Generator frequency must be correct.	Voltmeter should read at least 90% of nominal phase to phase voltage between transfer switch terminals EA and EC (or EL1 and EL2 for 2 pole switches). * * These are factory settings.
For 3ATS the transfer switch does not transfer the load to normal source when normal returns or after transfer test.	Wait for the feature 3A time delay. For immediate retransfer, press the transfer button (bypass timer). If inphase transfer is active, wait for inphase condition. For 3NTS press the transfer button.	-	Voltmeter should read at least 90% of nominal phase to phase voltage between transfer switch terminals NB and NC, NC and NA, and NA and NB (or NL1 and NL2 for 2 pole switches). * * These are factory settings.
For 3ATS the generator does not stop after load retransfer to the normal source.	Wait for the feature 2E time delay.	Starting control must be in automatic position.	-
 Not in auto light is always on.	For 3NTS this light is <u>always</u> on, indicating it is a manual transfer switch.	-	-
 Alert light is on.	Read the display for more information. Refer to User's Guide 381333-400.	-	-

**INDEX**

**A**

alert light, 7  
 see User's Guide 381333-400  
 ASI is ASCO Services Inc.  
 800-800-2726(ASCO)  
 customercare@asco.com  
 automatic operation, 3ATS, 5  
 auxiliary circuits, 3

**B**

battery, 7

**C**

cables, power, 2  
 connections, 2, 3  
 controller  
 see User's Guide 381333-400  
 controller ground, 3  
 cooldown, generator, 5, 7

**D**

**DANGER** statements, 1, 2, 4, 6

**E**

electrical operation, 5  
 emergency source accepted light,  
 4, 5  
 engine starting contacts, 3

**F**

foundation, 2  
 frequency, 7  
 functional test, 3

**G**

generator, 3, 4, 5, 7  
 ground, controller, 3

**H**

harness, 3  
 HELP 800-800-2726(ASCO)  
 customercare@asco.com

**I**

inphase transfer feature, 5, 7  
 inspection, 6  
 installation, 2  
 insulator backing piece, 2  
**WARNING**, 2

**L**

lights, 4, 5, 7  
 line connections, 2  
 load on emergency light, 4, 5  
 load on normal light, 4, 5  
 lubrication, 6

**M**

maintenance, 6  
 maintenance handle, 3, 6  
**WARNING**, 3, 6  
 manual load transfer, 6  
**WARNING**, 3, 6  
 manual operation, 3  
**WARNING**, 3, 6  
 manual transfer, 3NTS, 5  
 membrane controls, 4, 5  
 mounting, 2

**N**

non-automatic 3NTS, 5, 7  
 normal source accepted light, 4, 5  
 not in auto light, 7

**O**

operation, electrical, 5

**P**

phase rotation, 4  
 preventive maintenance, 6  
 problem, 7

**R**

rating label, 1  
 replacement parts, 6  
 retransfer button, 5, 7

**S**

source acceptable lights, 4, 5  
 starting contacts, 3  
 starting control, 7  
 starting problem, 4, 7  
 stopping problem, 7

**T**

terminals, 2, 3  
 testing power conductors, 2  
 time delays, 5, 7  
 transfer button, 5, 7  
 transfer problem, 7  
 troubleshooting, 7

**V**

voltage checks, 4, 7

**W**

**WARNING** statements, 1, 3, 5, 6